

Kettenrad 1/2 x 5/16"

für Rollenketten
nach DIN-Nr. 8187
ISO/R 606

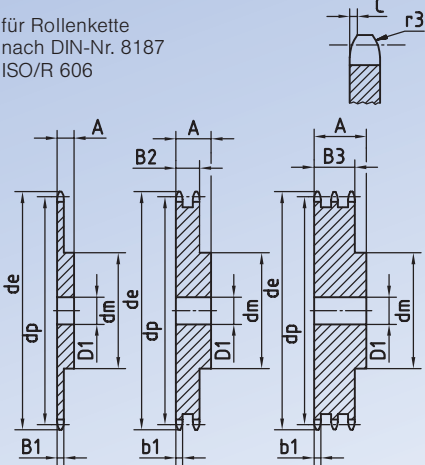

*Kettenräder mit angeschweißter Nabe

Kettenrad	ISO mm	ASA-40 mm
Zahnkopfrundung r ₃	13	13,5
Breite der Rundung C	1,3	1,6
Zahnkranzbreite B ₁	7,2	7,2
Zahnkranzbreite b ₁	7	7
Zahnkranzbreite B ₂	21	21,4
Zahnkranzbreite B ₃	34,9	35,8
Kette		
	mm	mm
Teilung	12,7	12,7
Innere Breite	7,75	7,94
Rollen-φ	8,51	7,94

Zähne- zahl Z	Abmessungen in mm					Artikel-Nr. Ketten Fuchs					
	allgemein		321-240- (+Zähnezahl)			322-240- (+Zähnezahl)			323-240- (+Zähnezahl)		
	de	dp	dm	einfach D1	A	dm	zweifach D1	A	dm	dreifach D1	A
008	37,2	33,18	20,0	10,0	25,0	20,0	10,0	32,0	20,0	10,0	46,0
009	41,0	37,13	24,0	10,0	25,0	24,0	10,0	32,0	24,0	12,0	46,0
010	45,2	41,10	26,0	10,0	25,0	28,0	10,0	32,0	28,0	12,0	46,0
011	48,7	45,07	29,0	10,0	25,0	32,0	12,0	35,0	32,0	14,0	50,0
012	53,0	49,07	33,0	10,0	28,0	35,0	12,0	35,0	35,0	14,0	50,0
013	57,4	53,06	37,0	10,0	28,0	38,0	12,0	35,0	38,0	14,0	50,0
014	61,8	57,07	41,0	10,0	28,0	42,0	12,0	35,0	42,0	14,0	50,0
015	65,5	61,09	45,0	10,0	28,0	46,0	12,0	35,0	46,0	14,0	50,0
016	69,5	65,10	50,0	12,0	28,0	50,0	14,0	35,0	50,0	16,0	50,0
017	73,6	69,11	52,0	12,0	28,0	54,0	14,0	35,0	54,0	16,0	50,0
018	77,8	73,14	56,0	12,0	28,0	58,0	14,0	35,0	58,0	16,0	50,0
019	81,7	77,16	60,0	12,0	28,0	62,0	14,0	35,0	62,0	16,0	50,0
020	85,8	81,19	64,0	12,0	28,0	66,0	14,0	35,0	66,0	16,0	50,0
021	89,7	85,22	68,0	12,0	28,0	70,0	16,0	40,0	70,0	20,0	55,0
022	93,8	89,24	70,0	12,0	28,0	70,0	16,0	40,0	70,0	20,0	55,0
023	98,2	93,27	70,0	14,0	28,0	70,0	16,0	40,0	70,0	20,0	55,0
024	101,8	97,29	70,0	14,0	28,0	75,0	16,0	40,0	75,0	20,0	55,0
025	105,8	101,33	70,0	14,0	28,0	80,0	16,0	40,0	80,0	20,0	55,0
026	110,0	105,36	70,0	16,0	30,0	85,0	20,0	40,0	85,0	20,0	55,0
027	114,0	109,40	70,0	16,0	30,0	85,0	20,0	40,0	85,0	20,0	55,0
028	118,0	113,42	70,0	16,0	30,0	90,0	20,0	40,0	90,0	20,0	55,0
029	122,0	117,46	80,0	16,0	30,0	95,0	20,0	40,0	95,0	20,0	55,0
030	126,1	121,50	80,0	16,0	30,0	100,0	20,0	40,0	100,0	20,0	55,0
031	130,2	125,54	90,0	16,0	30,0	100,0	20,0	40,0	110,0	20,0	55,0
032	134,3	129,56	90,0	16,0	30,0	100,0	20,0	40,0	110,0	20,0	55,0
033	138,4	133,60	90,0	16,0	30,0	100,0	20,0	40,0	110,0	20,0	55,0
034	142,6	137,64	90,0	16,0	30,0	100,0	20,0	40,0	110,0	20,0	55,0
035	146,7	141,68	90,0	16,0	30,0	100,0	20,0	40,0	110,0	20,0	55,0
036	151,0	145,72	90,0	16,0	35,0	110,0	20,0	40,0	120,0	25,0	55,0
037	154,6	149,76	90,0	16,0	35,0	110,0	20,0	40,0	120,0	25,0	55,0
038	158,6	153,80	90,0	16,0	35,0	110,0	20,0	40,0	120,0	25,0	55,0
039	162,7	157,83	90,0	16,0	35,0	110,0	20,0	40,0	120,0	25,0	55,0
040	166,8	161,87	90,0	16,0	35,0	110,0	20,0	40,0	120,0	25,0	55,0

Kettenradscheibe 1/2 x 5/16"

für Rollenketten
nach DIN-Nr. 8187
ISO/R 606

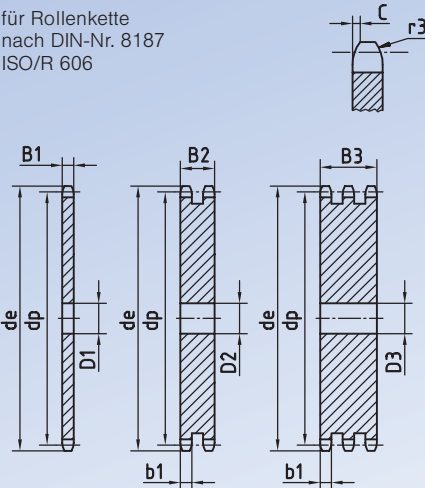

Kettenradscheibe	ISO mm	ASA-40 mm
Zahnkopfrundung r ₃	13	13,5
Breite der Rundung C	1,3	1,6
Zahnkranzbreite B ₁	7,2	7,2
Zahnkranzbreite b ₁	7	7
Zahnkranzbreite B ₂	21	21,4
Zahnkranzbreite B ₃	34,9	35,8
Kette		
	mm	mm
Teilung	12,7	12,7
Innere Breite	7,75	7,94
Rollen-φ	8,51	7,94

Zähne- zahl Z	Abmessungen in mm			Artikel-Nr. Ketten Fuchs 311-240- 312-240- 313-240- (+Zähnezahl)			Zähne- zahl Z	Abmessungen in mm			Artikel-Nr. Ketten Fuchs 311-240- 312-240- 313-240- (+Zähnezahl)		
	allgemein			einfach	zweifach	dreifach		allgemein			einfach	zweifach	dreifach
	de	dp	D1	D2	D3	D1		D2	D3	D1	D2	D3	
008	37,2	33,18	8,0	10,0	10,0	044	183,8	178,03	20,0	20,0	25,0		
009	41,0	37,13	8,0	10,0	12,0	045	188,0	182,70	20,0	20,0	25,0		
010	45,2	41,10	8,0	10,0	12,0	046	192,1	186,10	20,0	20,0	25,0		
011	48,7	45,07	10,0	12,0	14,0	047	198,2	190,14	20,0	20,0	25,0		
012	53,0	49,07	10,0	12,0	14,0	048	200,3	194,18	20,0	20,0	25,0		
013	57,4	53,06	10,0	12,0	14,0	049	204,3	198,22	20,0	20,0	25,0		
014	61,8	57,07	10,0	12,0	14,0	050	208,3	202,26	20,0	20,0	25,0		
015	65,5	61,09	10,0	12,0	14,0	051	212,2	206,30	20,0	25,0	25,0		
016	69,5	65,10	10,0	14,0	16,0	052	216,1	210,34	20,0	25,0	25,0		
017	73,6	69,11	10,0	14,0	16,0	053	220,2	214,37	20,0	25,0	25,0		
018	77,8	73,14	10,0	14,0	16,0	054	224,1	218,43	20,0	25,0	25,0		
019	81,7	77,16	10,0	14,0	16,0	055	228,1	222,46	20,0	25,0	25,0		
020	85,8	81,19	10,0	14,0	16,0	056	232,2	226,50	20,0	25,0	25,0		
021	89,7	85,22	12,0	16,0	20,0	057	236,4	230,54	20,0	25,0	25,0		
022	93,8	89,24	12,0	16,0	20,0	058	240,5	234,58	20,0	25,0	25,0		
023	98,2	93,27	12,0	16,0	20,0	059	244,5	238,62	20,0	25,0	25,0		
024	101,8	97,29	12,0	16,0	20,0	060	248,6	242,66	20,0	25,0	25,0		
025	105,8	101,33	12,0	16,0	20,0	062	256,9	250,75	25,0	25,0	25,0		
026	110,0	105,36	16,0	16,0	20,0	064	265,1	258,82	25,0	25,0	25,0		
027	114,0	109,40	16,0	16,0	20,0	065	269,0	262,86	25,0	25,0	25,0		
028	118,0	113,42	16,0	16,0	20,0	066	273,0	266,90	25,0	25,0	25,0		
029	122,0	117,46	16,0	16,0	20,0	068	281,0	274,99	25,0	25,0	25,0		
030	126,1	121,50	16,0	16,0	20,0	070	289,0	283,07	25,0	25,0	25,0		
031	130,2	125,54	16,0	16,0	20,0	072	297,2	291,16	25,0	25,0	25,0		
032	134,3	129,56	16,0	16,0	20,0	075	309,2	303,27	25,0	25,0	25,0		
033	138,4	133,60	16,0	16,0	20,0	076	313,3	307,33	25,0	25,0	25,0		
034	142,6	137,64	16,0	16,0	20,0	078	321,4	315,40	25,0	25,0	25,0		
035	146,7	141,68	16,0	16,0	20,0	080	329,4	323,48	25,0	25,0	25,0		
036	151,0	145,72	16,0	20,0	25,0	085	349,0	343,70	25,0	25,0	25,0		
037	154,6	149,76	16,0	20,0	25,0	090	369,9	363,90	25,0	25,0	25,0		
038	158,6	153,80	16,0	20,0	25,0	095	390,1	384,11	25,0	25,0	25,0		
039	162,7	157,83	16,0	20,0	25,0	100	410,3	404,32	25,0	25,0	25,0		
040	166,8	161,87	16,0	20,0	25,0	110	450,7	444,74	25,0	25,0	25,0		
041	171,4	165,91	20,0	20,0	25,0	114	466,9	460,90	25,0	25,0	25,0		
042	175,4	169,95	20,0	20,0	25,0	120	491,2	485,16	25,0	25,0	25,0		
043	179,7	173,99	20,0	20,0	25,0	125	511,3	505,37	25,0	25,0	25,0		