

Kettenrad 1/2 × 1/8"

für Rollenkette
nach DIN-Nr. 8187
ISO/R 606

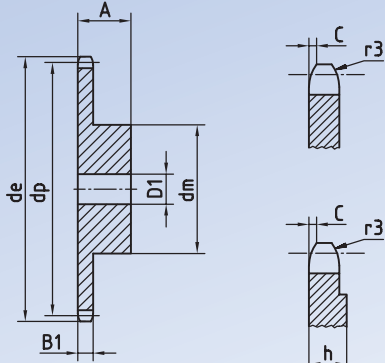

ab Z=31
h=4 mm

Kettenrad	mm
Zahnkopfrundung r3	13
Breite der Rundung C	1,0
Zahnkranzbreite B ₁	3
Kette	mm
Teilung	12,7
Innere Breite	3,3
Rollen-φ	7,75

Zähnezahl Z	Abmessungen in mm allgemein		Artikel-Nr. Ketten Fuchs		
	de	dp	321-210- (+Zähnezahl)		
			einfach	D1	A
008	37,3	33,18	21,0	8,0	14,0
009	41,5	37,13	25,0	8,0	14,0
010	46,2	41,10	28,0	8,0	14,0
011	49,6	45,07	31,0	8,0	16,0
012	53,9	49,07	35,0	8,0	16,0
013	58,4	53,06	39,0	8,0	16,0
014	62,8	57,07	43,0	8,0	16,0
015	66,8	61,09	47,0	8,0	16,0
016	70,9	65,10	50,0	10,0	18,0
017	74,9	69,11	50,0	10,0	18,0
018	78,9	73,14	50,0	10,0	18,0
019	82,9	77,16	50,0	10,0	18,0
020	86,9	81,19	50,0	10,0	18,0
021	91,0	85,22	60,0	12,0	20,0
022	95,0	89,24	60,0	12,0	20,0
023	99,0	93,27	60,0	12,0	20,0
024	103,0	97,29	60,0	12,0	20,0
025	107,1	101,33	60,0	12,0	20,0
026	111,2	105,36	70,0	16,0	20,0
027	115,4	109,40	70,0	16,0	20,0
028	119,4	113,42	70,0	16,0	20,0
029	123,4	117,46	70,0	16,0	20,0
030	127,5	121,50	70,0	16,0	20,0
031	131,5	125,54	70,0	16,0	20,0
032	135,5	129,56	70,0	16,0	20,0
033	139,6	133,60	70,0	16,0	20,0
034	143,6	137,64	70,0	16,0	20,0
035	147,6	141,68	70,0	16,0	20,0
036	151,7	145,72	70,0	16,0	25,0
037	155,7	149,76	70,0	16,0	25,0
038	159,8	153,80	70,0	16,0	25,0
039	163,8	157,83	70,0	16,0	25,0
040	167,8	161,87	70,0	16,0	25,0

Kettenradscheibe 1/2 × 1/8"

für Rollenkette
nach DIN-Nr. 8187
ISO/R 606

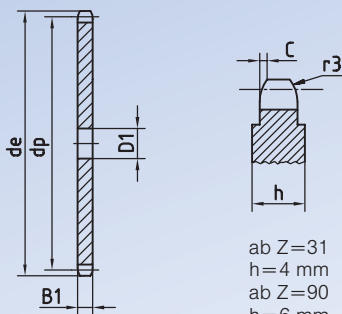

ab Z=31
h=4 mm
ab Z=90
h=6 mm

Kettenradscheibe	mm
Zahnkopfrundung r3	13
Breite der Rundung C	1,0
Zahnkranzbreite B ₁	3
Kette	mm
Teilung	12,7
Innere Breite	3,3
Rollen-φ	7,75

Zähnezahl Z	Abmessungen in mm allgemein		Artikel-Nr. Ketten Fuchs 311-210- (+Zähnezahl) einfach D1	Zähnezahl Z	Abmessungen in mm allgemein		Artikel-Nr. Ketten Fuchs 311-210- (+Zähnezahl) einfach D1
	de	dp			de	dp	
008	37,3	33,18	8,0	044	183,5	178,03	16,0
009	41,5	37,13	8,0	045	187,5	182,70	16,0
010	46,2	41,10	8,0	046	191,6	186,10	20,0
011	49,6	45,07	8,0	047	195,6	190,14	20,0
012	53,9	49,07	8,0	048	199,7	194,18	20,0
013	58,4	53,06	8,0	049	203,7	198,22	20,0
014	62,8	57,07	8,0	050	207,8	202,26	20,0
015	66,8	61,09	8,0	051	211,8	206,30	20,0
016	70,9	65,10	10,0	052	215,9	210,34	20,0
017	74,9	69,11	10,0	053	219,9	214,37	20,0
018	78,9	73,14	10,0	054	224,0	218,43	20,0
019	82,9	77,16	10,0	055	228,0	222,46	20,0
020	86,9	81,19	10,0	056	232,1	226,50	20,0
021	91,0	85,22	10,0	057	236,1	230,54	20,0
022	95,0	89,24	10,0	058	240,2	234,58	20,0
023	99,0	93,27	10,0	059	244,2	238,62	20,0
024	103,0	97,29	10,0	060	248,2	242,66	20,0
025	107,1	101,33	10,0	062	256,7	250,75	20,0
026	111,2	105,36	12,0	064	264,8	258,82	20,0
027	115,4	109,40	12,0	065	268,8	262,86	20,0
028	119,4	113,42	12,0	066	272,9	266,90	25,0
029	123,4	117,46	12,0	068	280,9	274,99	25,0
030	127,5	121,50	12,0	070	289,0	283,07	25,0
031	131,5	125,54	12,0	072	297,1	291,16	25,0
032	135,5	129,56	12,0	076	313,3	307,33	25,0
033	139,6	133,60	12,0	078	321,4	315,40	25,0
034	143,6	137,64	12,0	080	329,4	323,48	25,0
035	147,6	141,68	12,0	085	349,7	343,70	25,0
036	151,7	145,72	16,0	090	369,9	363,90	25,0
037	155,7	149,76	16,0	095	390,1	384,10	25,0
038	159,8	153,80	16,0	100	410,3	404,31	25,0
039	163,8	157,83	16,0	110	450,7	444,74	25,0
040	167,8	161,87	16,0	114	466,9	460,90	25,0
041	171,0	165,91	16,0	120	491,2	485,16	25,0
042	175,4	169,95	16,0	125	511,4	505,37	25,0
043	179,5	173,99	16,0				