

Kettenrad 8 x 3 mm

für Rollenkette
nach DIN-Nr. 8187
ISO/R 606 – ANSI B 29.1

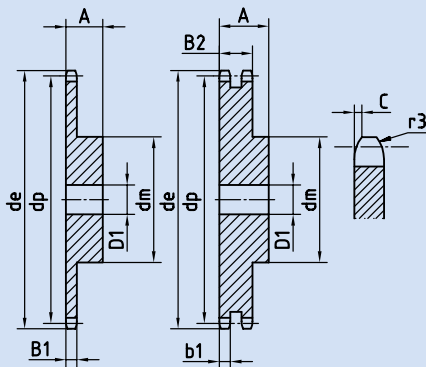

Kettenrad	mm
Zahnkopfrundung r_3	8
Breite der Rundung C	1,0
Zahnkranzbreite B_1	2,8
Zahnkranzbreite b_1	2,7
Zahnkranzbreite B_2	8,3
Kette	mm
Teilung	8
Innere Breite	3
Rollen- ϕ	5

Kettenradscheibe 8 x 3 mm

für Rollenkette
nach DIN-Nr. 8187
ISO/R 606

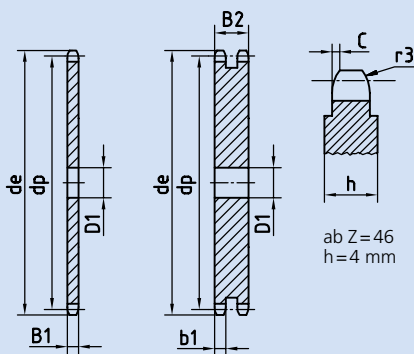

Kettenradscheibe	mm
Zahnkopfrundung r_3	8
Breite der Rundung C	1,0
Zahnkranzbreite B_1	2,8
Zahnkranzbreite b_1	2,7
Zahnkranzbreite B_2	8,3
Kette	mm
Teilung	8
Innere Breite	3
Rollen- ϕ	5

Zähnezahl	Abmessungen in mm allgemein		Artikel-Nr. Ketten Fuchs					
	de	dp	321-020- (+Zähnezahl)			322-020- (+Zähnezahl)		
Z			dm	D1	A	dm	D1	A
008	24,0	20,90	13,0	6,0	12,0	12,0	8,0	18,0
009	26,6	23,39	15,0	6,0	12,0	15,0	8,0	18,0
010	29,2	25,89	17,0	8,0	12,0	17,0	8,0	18,0
011	31,7	28,39	18,0	8,0	13,0	19,0	10,0	18,0
012	34,2	30,91	20,0	8,0	13,0	21,0	10,0	18,0
013	36,7	33,42	23,0	8,0	13,0	24,0	10,0	18,0
014	39,2	35,95	25,0	8,0	13,0	26,0	10,0	18,0
015	41,7	38,48	28,0	8,0	13,0	29,0	10,0	18,0
016	44,3	41,01	30,0	8,0	14,0	32,0	10,0	20,0
017	46,8	43,53	30,0	8,0	14,0	34,0	10,0	20,0
018	49,3	46,07	30,0	8,0	14,0	37,0	10,0	20,0
019	51,9	48,61	30,0	8,0	14,0	39,0	10,0	20,0
020	54,4	51,14	30,0	8,0	14,0	40,0	10,0	20,0
021	57,0	53,68	35,0	8,0	14,0	40,0	10,0	20,0
022	59,5	56,21	35,0	8,0	14,0	40,0	10,0	20,0
023	62,0	58,75	35,0	8,0	14,0	40,0	10,0	20,0
024	64,6	61,29	35,0	8,0	14,0	40,0	10,0	20,0
025	67,5	63,83	35,0	8,0	14,0	40,0	10,0	20,0
026	69,5	66,37	40,0	10,0	16,0	50,0	12,0	22,0
027	72,2	68,91	40,0	10,0	16,0	50,0	12,0	22,0
028	74,8	71,45	40,0	10,0	16,0	50,0	12,0	22,0
029	77,3	73,99	40,0	10,0	16,0	50,0	12,0	22,0
030	79,8	76,53	40,0	10,0	16,0	50,0	12,0	22,0
031	82,4	79,08	40,0	10,0	16,0	60,0	12,0	22,0
032	84,9	81,61	40,0	10,0	16,0	60,0	12,0	22,0
033	87,5	84,16	40,0	10,0	16,0	60,0	12,0	22,0
034	90,0	86,70	40,0	10,0	16,0	60,0	12,0	22,0
035	92,5	89,25	40,0	10,0	16,0	60,0	12,0	22,0
036	95,0	91,79	40,0	10,0	16,0	60,0	12,0	22,0
037	97,6	94,33	40,0	10,0	16,0	60,0	12,0	22,0
038	100,2	96,88	40,0	10,0	16,0	60,0	12,0	22,0
039	102,7	99,42	40,0	10,0	16,0	60,0	12,0	22,0
040	105,3	101,97	40,0	10,0	16,0	60,0	12,0	22,0

Zähnezahl	Abmessungen in mm allgemein		Artikel-Nr. Ketten Fuchs 311-020- 312-020- (+Zähnezahl)		Z	Abmessungen in mm allgemein		Artikel-Nr. Ketten Fuchs 311-020- 312-020- (+Zähnezahl)	
	de	dp	einfach D1	zweifach D2		de	dp	einfach D1	zweifach D2
008	24,0	20,90	6,0	6,0	044	115,5	112,14	12,0	14,0
009	26,6	23,39	6,0	6,0	045	118,0	114,69	12,0	14,0
010	29,2	25,89	8,0	8,0	046	120,6	117,23	12,0	14,0
011	31,7	28,39	8,0	8,0	047	123,1	119,77	12,0	14,0
012	34,2	30,91	8,0	8,0	048	125,6	122,32	12,0	14,0
013	36,7	33,42	8,0	8,0	049	128,2	124,86	12,0	14,0
014	39,2	35,95	8,0	8,0	050	130,7	127,41	12,0	14,0
015	41,7	38,48	8,0	8,0	051	133,3	129,95	14,0	16,0
016	44,3	41,01	8,0	10,0	052	135,8	132,49	14,0	16,0
017	46,8	43,53	8,0	10,0	053	138,4	135,04	14,0	16,0
018	49,3	46,07	8,0	10,0	054	140,9	137,59	14,0	16,0
019	51,9	48,61	8,0	10,0	055	143,5	140,13	14,0	16,0
020	54,4	51,14	8,0	10,0	056	146,0	142,68	14,0	16,0
021	57,0	53,68	8,0	10,0	057	148,6	145,22	14,0	16,0
022	59,5	56,21	8,0	10,0	058	151,0	147,77	14,0	16,0
023	62,0	58,75	8,0	10,0	059	153,6	150,31	14,0	16,0
024	64,6	61,29	8,0	10,0	060	156,2	152,85	14,0	16,0
025	67,5	63,83	8,0	10,0	062	162,0	157,95	16,0	20,0
026	69,5	66,37	10,0	12,0	064	167,1	163,04	16,0	20,0
027	72,2	68,91	10,0	12,0	065	169,6	165,58	16,0	20,0
028	74,8	71,45	10,0	12,0	066	172,2	168,13	16,0	20,0
029	77,3	73,99	10,0	12,0	068	177,3	173,22	16,0	20,0
030	79,8	76,53	10,0	12,0	070	182,4	178,31	16,0	20,0
031	82,4	79,08	10,0	12,0	072	187,5	183,41	20,0	20,0
032	84,9	81,61	10,0	12,0	075	195,1	191,04	20,0	20,0
033	87,5	84,16	10,0	12,0	076	197,7	193,59	20,0	20,0
034	90,0	86,70	10,0	12,0	078	202,8	198,68	20,0	20,0
035	92,5	89,25	10,0	12,0	080	207,9	203,77	20,0	20,0
036	95,0	91,79	10,0	12,0	085	220,6	216,50	20,0	20,0
037	97,6	94,33	10,0	12,0	090	233,4	229,23	20,0	20,0
038	100,2	96,88	10,0	12,0	095	246,1	241,96	20,0	20,0
039	102,7	99,42	10,0	12,0	100	258,9	254,68	20,0	20,0
040	105,3	101,97	10,0	12,0	110	284,3	280,15	20,0	20,0
041	107,8	104,51	12,0	14,0	114	294,5	290,33	20,0	20,0
042	110,4	107,05	12,0	14,0	120	310,0	305,61	20,0	20,0
043	112,9	109,60	12,0	14,0	125	322,5	318,34	20,0	20,0