

Zahnriemenscheiben (metrische AT-Teilung)

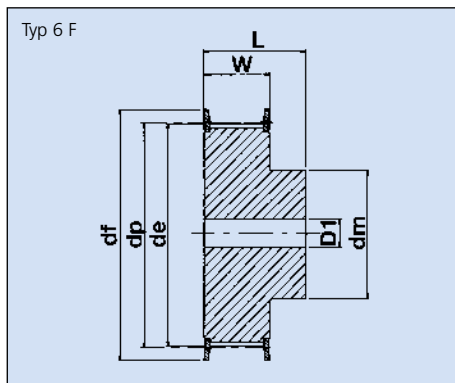
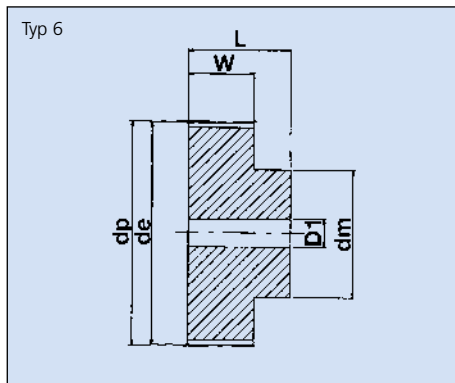

AT 5 (Teilung = 5 mm) – für Zahnriemenbreite = 16 mm

Artikel-Nr. Ketten Fuchs	Zähne- zahl	Typ	Werk- stoff	Abmessungen in mm							
				de	dp	dm	Di	df	W	L	D1
27AT5/12-2	12	6F	Al	17,85	19,10	11,0	–	23,0	21,0	27,0	–
27AT5/14-2	14	6F	Al	21,05	22,29	13,0	–	25,0	21,0	27,0	–
27AT5/15-2	15	6F	Al	22,65	23,88	16,0	–	28,0	21,0	27,0	6,0
27AT5/16-2	16	6F	Al	24,20	25,47	18,0	–	32,0	21,0	27,0	6,0
27AT5/18-2	18	6F	Al	27,40	28,65	20,0	–	32,0	21,0	27,0	6,0
27AT5/19-2	19	6F	Al	29,00	30,25	22,0	–	36,0	21,0	27,0	6,0
27AT5/20-2	20	6F	Al	30,60	31,83	23,0	–	36,0	21,0	27,0	6,0
27AT5/22-2	22	6F	Al	33,85	35,02	24,0	–	38,0	21,0	27,0	6,0
27AT5/24-2	24	6F	Al	37,00	38,21	26,0	–	42,0	21,0	27,0	6,0
27AT5/25-2	25	6F	Al	38,60	39,8	26,0	–	44,0	21,0	27,0	6,0
27AT5/26-2	26	6F	Al	40,20	41,39	26,0	–	44,0	21,0	27,0	6,0
27AT5/27-2	27	6F	Al	41,80	42,98	30,0	–	48,0	21,0	27,0	8,0
27AT5/28-2	28	6F	Al	43,35	44,58	32,0	–	48,0	21,0	27,0	8,0
27AT5/30-2	30	6F	Al	46,55	47,76	34,0	–	51,0	21,0	27,0	8,0
27AT5/32-2	32	6F	Al	49,70	50,94	38,0	–	54,0	21,0	27,0	8,0
27AT5/36-2	36	6F	Al	56,05	57,31	38,0	–	64,0	21,0	27,0	8,0
27AT5/40-2	40	6F	Al	62,45	63,66	40,0	–	66,5	21,0	27,0	8,0
27AT5/42-2	42	6F	Al	65,60	66,86	40,0	–	70,0	21,0	27,0	8,0
27AT5/44-0	44	6	Al	68,80	70,05	45,0	–	–	21,0	27,0	8,0
27AT5/48-0	48	6	Al	75,15	76,42	50,0	–	–	21,0	27,0	8,0
27AT5/60-0	60	6	Al	94,25	95,52	65,0	–	–	21,0	27,0	8,0

AT 5 (Teilung = 5 mm) – für Zahnriemenbreite = 25 mm

Artikel-Nr. Ketten Fuchs	Zähne- zahl	Typ	Werk- stoff	Abmessungen in mm							
				de	dp	dm	Di	df	W	L	D1
36AT5/12-2	12	6F	Al	17,85	19,10	11,0	–	23,0	30,0	36,0	–
36AT5/14-2	14	6F	Al	21,05	22,29	13,0	–	25,0	30,0	36,0	–
36AT5/15-2	15	6F	Al	22,65	23,88	16,0	–	28,0	30,0	36,0	6,0
36AT5/16-2	16	6F	Al	24,20	25,47	18,0	–	32,0	30,0	36,0	6,0
36AT5/18-2	18	6F	Al	27,40	28,65	20,0	–	32,0	30,0	36,0	6,0
36AT5/19-2	19	6F	Al	29,00	30,25	22,0	–	36,0	30,0	36,0	6,0
36AT5/20-2	20	6F	Al	30,60	31,83	23,0	–	36,0	30,0	36,0	6,0
36AT5/22-2	22	6F	Al	33,85	35,02	24,0	–	38,0	30,0	36,0	6,0
36AT5/24-2	24	6F	Al	37,00	38,21	26,0	–	42,0	30,0	36,0	6,0
36AT5/25-2	25	6F	Al	38,60	39,80	26,0	–	44,0	30,0	36,0	6,0
36AT5/26-2	26	6F	Al	40,20	41,39	26,0	–	44,0	30,0	36,0	6,0
36AT5/27-2	27	6F	Al	41,80	42,98	30,0	–	48,0	30,0	36,0	8,0
36AT5/28-2	28	6F	Al	43,35	44,58	32,0	–	48,0	30,0	36,0	8,0
36AT5/30-2	30	6F	Al	46,55	47,76	34,0	–	51,0	30,0	36,0	8,0
36AT5/32-2	32	6F	Al	49,70	50,94	38,0	–	54,0	30,0	36,0	8,0
36AT5/36-2	36	6F	Al	56,05	57,31	38,0	–	64,0	30,0	36,0	8,0
36AT5/40-2	40	6F	Al	62,45	63,66	40,0	–	66,5	30,0	36,0	8,0
36AT5/42-2	42	6F	Al	65,60	66,86	40,0	–	70,0	30,0	36,0	8,0
36AT5/44-0	44	6	Al	68,80	70,05	45,0	–	–	30,0	36,0	8,0
36AT5/48-0	48	6	Al	75,15	76,42	50,0	–	–	30,0	36,0	8,0
36AT5/60-0	60	6	Al	94,25	95,52	65,0	–	–	30,0	36,0	8,0

AT 10 (Teilung = 10 mm) – für Zahnriemenbreite = 16 mm

Artikel-Nr. Ketten Fuchs	Zähne- zahl	Typ	Werk- stoff	Abmessungen in mm							
				de	dp	dm	Di	df	W	L	D1
31AT10/15-2	15	6F	Al	45,90	47,75	32,0	–	51,0	21,0	31,0	8,0
31AT10/16-2	16	6F	Al	49,05	50,93	35,0	–	54,0	21,0	31,0	8,0
31AT10/18-2	18	6F	Al	55,45	57,29	40,0	–	60,0	21,0	31,0	8,0
31AT10/19-2	19	6F	Al	58,60	60,48	44,0	–	66,5	21,0	31,0	8,0
31AT10/20-2	20	6F	Al	61,80	63,66	46,0	–	66,5	21,0	31,0	8,0
31AT10/22-2	22	6F	Al	68,15	70,03	52,0	–	75,0	21,0	31,0	8,0
31AT10/24-2	24	6F	Al	74,55	76,39	58,0	–	83,0	21,0	31,0	8,0
31AT10/25-2	25	6F	Al	77,70	79,58	60,0	–	83,0	21,0	31,0	8,0
31AT10/26-2	26	6F	Al	80,90	82,76	60,0	–	87,0	21,0	31,0	8,0
31AT10/27-2	27	6F	Al	84,10	85,95	60,0	–	91,0	21,0	31,0	8,0
31AT10/28-2	28	6F	Al	87,25	89,12	60,0	–	93,0	21,0	31,0	8,0
31AT10/30-2	30	6F	Al	93,65	95,49	60,0	–	102,0	21,0	31,0	8,0
31AT10/32-2	32	6F	Al	100,00	101,86	65,0	–	106,0	21,0	31,0	10,0
31AT10/31-2	36	6F	Al	112,75	114,59	70,0	–	119,0	21,0	31,0	10,0
31AT10/40-2	40	6F	Al	125,45	127,32	80,0	–	131,0	21,0	31,0	10,0
31AT10/44-0	44	6	Al	138,20	140,05	88,0	–	–	21,0	31,0	10,0
31AT10/48-0	48	6	Al	150,95	152,78	95,0	–	–	21,0	31,0	16,0
31AT10/60-0	60	6	Al	189,10	190,98	110,0	–	–	21,0	31,0	16,0

Bestellbeispiel

40	AT 10/30-2	Scheibenbreite (L)
		Teilung 10 mm
		Zähnezahl
		mit Bordscheiben
		ohne Bordscheiben

lieferbar:

- mit Vorbohrung (siehe Maß d)
- mit Fertigbohrung und Nut nach DIN-Nr. 6885 (gemäß Ihren Angaben)